



SERIES

280 · 310 · 350



MJP

A FORCE TO TRUST

INTRODUCING THE X SERIES

We are pleased to present the latest innovation in waterjet technology – the X Series. Born from the ambition to create the highest performing waterjet on the market, the X Series has been expertly engineered for demanding applications by combining the best characteristics of MJPs proven mixed-flow product line with the highly respected Ultrajet series.

Featuring the proven MJP duplex steel, mixed-flow pump, our unique technology reduces power demand by 20 percent compared to rival offers. Its superior construction is not only light weight but durable with unmatched strength, easily withstanding debris. A true workhorse for the toughest applications on the water.

Designed for builders and operators, by builders and operators, we've taken into account the importance of the total cost of ownership. Which is why the X Series has been designed with

lifecycle costs in mind, from easy installation to accessibility for maintenance in the field. Additionally, we've designed a highly efficient jet that boasts the TBO of a commercially rated engine with the weight and power of a yacht rated engine – translating into fuel consumption savings as well.

Welcome to the next generation of waterjet technology.
Meet the X Series.



Magnus Sörenson, CEO

MEET THE X SERIES

Enhanced reversing bucket

The cast aluminum bucket has been designed for improved stopping distance and increased maneuverability. With its new narrow design, center-to-center installation placement is minimized and the mechanical tie bar synchronizes steering in helm pump installations.

New steering fin design

The new hydrodynamically designed steering fin gives superior responsiveness and steering efficiency, all while eliminating dead band. Combined with a balanced steering nozzle for small maneuvering forces, enables control by hydraulic helm pump.

Designed for optional interceptor integration

Fitted under the waterjet, the interceptor placement has been carefully integrated to complement the jet design. Its strategic location maximizes stagnation pressure under the hull, generating greater lift. Additional interceptors can be fitted on either side of the jet.

Proven mixed flow pump

Proven with more than 18 million running hours, our stainless steel, mixed flow pump has been expertly engineered to be the most efficient and durable pump ever built. Designed for high-speed applications well in excess of 50 knots, the X Series is optimized for high thrust even at low speeds – maximizing efficiencies across speed ranges. And because of its duplex stainless steel construction, it's not only faster, but also delivers more than double the yield strength of its aluminum counterparts.

Integrated hydraulic system

The all inboard integrated hydraulic system provides superior corrosion resistance and eliminates the risk of external oil spills. Featuring separated seals for water and oil, the X Series is compliant with clean-water regulatory requirements.

Optimized intake geometry

The superior high-speed characteristics of the pump allows optimized intake at lower speeds, thereby developing optimal performance over the complete speed range, without impacting top-speed capabilities.



KEY FEATURES



20 PERCENT

The highly efficient X Series reduces power demand by up to 20% – therefore builders can select lower installed power and deliver fuel and cost savings to operators.



50 KNOTS

Designed for applications in excess of 50 knots with improved efficiencies.



10 PERCENT LIGHTER

The X series is a true mixed flow pump making it possible to select a smaller jet thereby reducing the weight by up to 10 % compared to axial flow jets – translating into better fuel economy and cost savings.



BUILT TO LAST

MJP is known for our commitment to quality. That's why the best-in-class MJP five-year warranty comes standard with the X Series. It's our promise to you – unmatched quality, unsurpassed service and an unequalled customer experience.

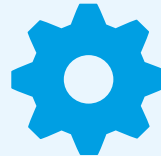

EASY MAINTENANCE

Designed with maintainability in mind, the X Series pump features a water lubricated thrust bearing and aft of transom inspection hatch for ease of maintenance in the field. And now operators can choose from tailored service solutions to maximize operational hours, because it's our business to keep your business up and running.



EASY INSTALLATION

The X Series has an optimized footprint that allows for greater flexibility in boat design and building. Its compact design offers one-piece installation making mounting to the hull as simple as bolting on or welding in. All hydraulics are pre-installed, no need for additional equipment or piping.

DIMENSIONS

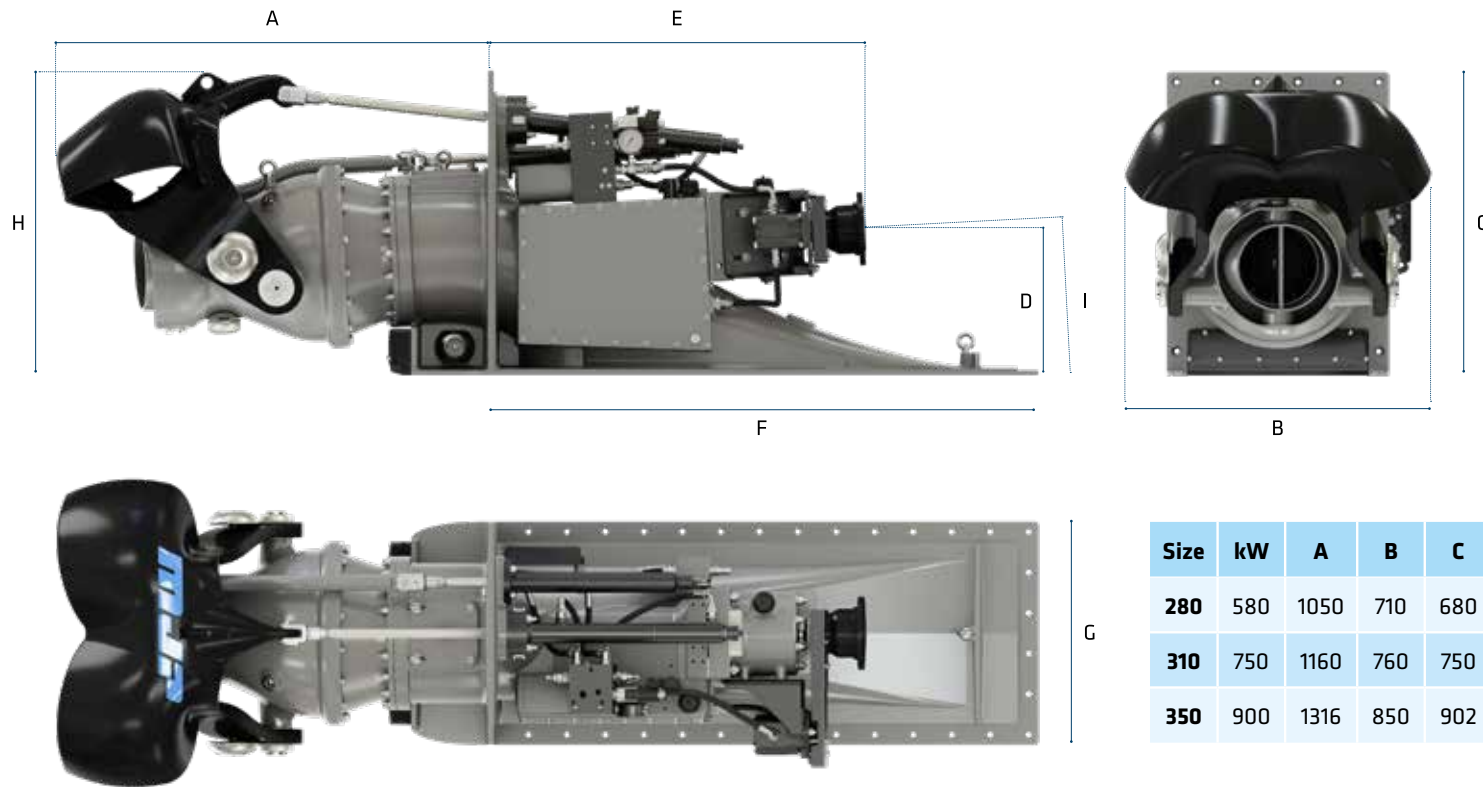

Size	kW	A	B	C	D	E	F	G	H	I
280	580	1050	710	680	330	870	1230	510	670	3 degrees
310	750	1160	760	750	360	930	1360	550	740	3 degrees
350	900	1316	850	902	400	1174	1689	620	916	0 degrees

PERFORMANCE

This unique technology reduces power demand by 20 percent compared to rival offers, enabling the manufacturer to select lower installed power without increasing displacement. For operators, this translates into speed and efficiency. The MJP X Series features our proprietary mixed flow pump – ideal for applications well in excess of 50 knots.

OPTIMAL EFFICIENCY

Taking into consideration the vessel's resistance at the desired speed, use our thrust envelope diagram as a guide in determining which X Series model is best for you. Thrust figures shown are for a single waterjet. For a twin installation, thrust is doubled.

*For best performance prediction contact MJP Sales

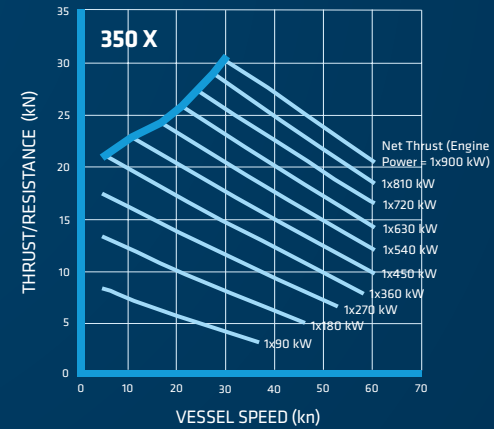
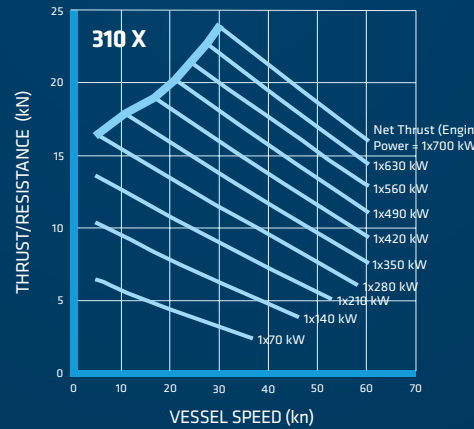
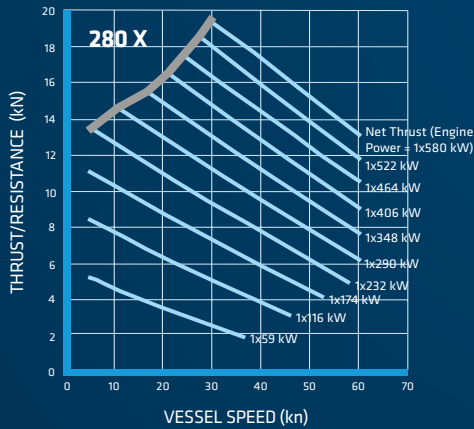
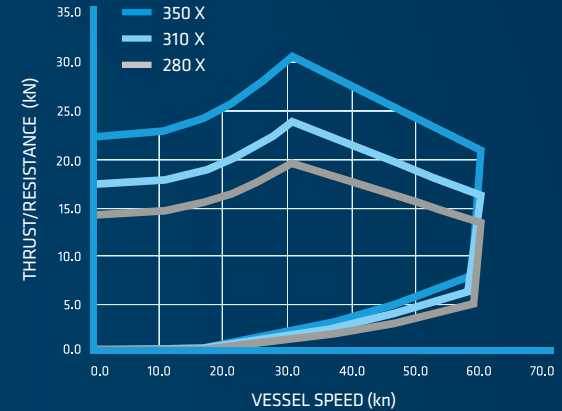

TAKE CONTROL

Because the world's best waterjet deserves the world's best control system, that's why we've created the Jetmaster. MJP controls offer the ultimate in flexibility, precision and customization. The Jetmaster's innovative modular control system gives users the very best in durable hardware and advanced software.

Our systems offer numerous options, such as additional steering stations, integration of interceptors and bow thrusters. MJP can also offer interfaces for unmanned and DP-controlled vessels and "black box" Voyage Data Recorder (VDR)

connection is available. Remote-control system service access is possible through the remote access module.

THE FREEDOM TO CHOOSE

With the X series, users have the option to choose between industry leading Jetmaster electronic controls or select hydromechanical controls. We can custom suit a controls package to fit your mission requirements.



COMBINATOR

Single or twin lever for forward and reverse thrust with optional engine RMP and clutch integration.



STEERING WHEEL

Port and starboard steering functionality plus optional tiller steer and armrest mounted intuitive autopilot integration.



CONTROL SCREEN

7 or 15-inch touch screen display for waterjet control and diagnostics.



VECTOR CONTROL SYSTEM

The VCS joystick offers full and true vector control in harbor or at slow speed, close quarter maneuvering. Clutch control is much often included as well as autopilot.

WORLDWIDE SERVICE



MJP Waterjets is known for its long lasting, heavy-duty products and has set the bar in marine propulsion with its five-year warranty. The MJP warranty is valid for material and workmanship, and only requires that service instructions are followed and original spare parts are used. It also remains valid if the ownership of a vessel changes. MJP's five-year warranty demonstrates our commitment to yards and operators.

USA

Marine Jet Power Inc.
6740 Commerce Court Drive
Blacklick, OH 43004-9200, USA
Phone: +1 (614) 759 90 00

SWEDEN

Marine Jet Power AB
Hansellsgatan 6
SE 754 50 Uppsala, Sweden
Phone: +46 (0) 10 165 10 00

AUSTRALIA

Perth
Phone: + 61 408 933 887



SOUTH KOREA

Marine Jet Power Korea Co.Ltd
#604 C1 I-Park, Marinecity 2-Ro 38
48120 Busan, Korea
Phone: +82 (51) 746 6428

SERVICE SOLUTIONS

Designed by the market for the market, the X Series is the culmination of over 30 years of industry experience. Developed in conjunction with designers, builders and operators, our goal is to be a full service propulsion partner – from initial design, through the build process to delivery and installation followed by many successful operational

years. A force to trust, it's our commitment to you and it starts with offering an industry leading 5 year warranty backed by world-class customer support and service. Choose from one of our service packages below or lets us custom build a solution to fit your operational needs.

	 SERVICE	 SERVICE PLUS	 SERVICE DIAMOND
5 year extended warranty	✓	✓	✓
Service schedule	✓	✓	✓
24 hour tech support	✓	✓	✓
Service engineer	✓	✓	✓
Discounted wear parts	✓	✓	✓
Critical spares within 5 days		✓	✓
Emergency assistance		✓	✓
Onboard training certification			✓
Critical spares within 24 hours			✓
Emergency assistance onsite 48 hours			✓

(Service Contracts are subject to terms and conditions.)

TESTIMONIALS

ITALIAN FAST FIGHTING CRAFT

BAGLIETTO SpA., one of Italy's best-known shipyards, is a leading naval vessel builder. Their recent acquisition by the Gavio Group led to the creation of the Baglietto Navy brand, which offers a wide range of military and governmental products.

The latest addition to their portfolio is the MNI 15. The first vessel of the series was launched in July 2016. MNI 15 is a multi-purpose nautical platform built in aluminum, widely customizable for different missions such as search and rescue, logistics, defense, patrol, prevention of human trafficking, unmanned, fire fighting etc.

MJP 300 was selected as the vessel's main propulsion unit as a result of its superior performance, best available acceleration, and its durability following after an extended and detailed design stage.

The Fast Fighting Craft (FCC) demonstrator built at Baglietto, is a troop transport vessel that hosts up to four crewmembers and 24 landing troops. Entrance/exit is via a bow ramp or rear access. The vessel features a reinforced prow for beaching operations, ballistic protection and even an anti-roll system.

Even though the vessel is heavily equipped, performance targets are met and acceleration is better than expected, with full speed being achieved in less than 30 seconds.

The MJP control system was integrated with an interceptor control platform utilizing the full potential of both systems. "With an electronic control system, we can hand over small course corrections, at higher speed, to the interceptors. This increases the overall propulsion efficiency and reduces fuel cost." – Says Joakim Adamsson, Product Manager.

BUILDER: Baglietto S.p.A., Italy	DISPL: 18 000 kg
LOA: 15.83 m	ENGINE POWER: 2 x 625 kW
BOA: 3.60 m	SPEED: 45 knots
DRAFT: 0.80 m	WATERJETS: MJP 300

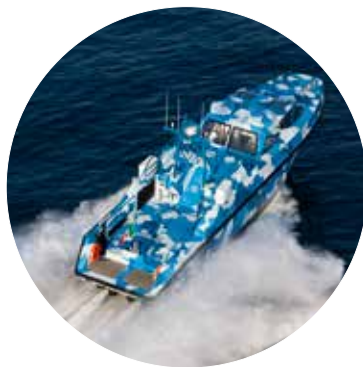

MJP 300 ON NORWEGIAN SAR BOATS

The RS 154 is the first in a series of 14-meter Fast Rescue Craft for the Norwegian Society for Sea Rescue (RS). The design comprises a 11.7-meter hull in FRP construction according to DNV HSLC rules, fitted with a resiliently mounted wheelhouse, equipped for Search and Rescue missions.

The vessel, which was originally delivered in 2014 by Swede Ship Marine, has now been upgraded with new MJP waterjets that feature integrated Humphree interceptors. Powered by Iveco N67 M56 diesel engines, the two MJP 300 waterjets develop top speeds in excess of 40kn.

Results from sea trials have been fantastic. Top speed is increased by 6kn – simply by replacing existing jets with the new MJP 300 design. As a bonus, noise levels in the wheelhouse dropped from 70dB(A) to less than 64dB(A) at cruising speeds of 34kn.

These successful results have resulted in all six boats being upgraded with, for example, the replacement of pod drive propulsion.



BUILDER: Swede Ship Marine	DISPL: 12 500 kg
LOA: 14.30 m	ENGINE POWER: 2 x 368 kW
BOA: 4.10 m	SPEED: 40 knots
DRAFT: 0.85 m	WATERJETS: MJP 300

CONTACT MARINE JET POWER INC.



Jukka Kukkula
Regional Director, EMEA
+358 44 591 00 34
jukka.kukkula@marinejetpower.com



Jordan Tilton
Regional Manager, Americas
+1 614 306 05 39
jordan.tilton@marinejetpower.com



Silver Park
Regional Director, South Korea
+82 10 3148 64 28
silver.park@marinejetpower.com



Paul Hague
Regional Director, APAC
+ 61 408 933 887
paul.hague@marinejetpower.com

MJP

A FORCE TO TRUST