

ULLMAN



PROTECTING PEOPLE

References



References



MORE REFERENCES ON BACK COVER

The Ullman heritage

In 1982 Johan Ullman M.D. served as the 1:st Surface Attack Flotilla doctor on board the Swedish destroyer HMS Halland.

Examining sailors that had served for 9 months on board the flotilla's Motor-Torpedo boats, he found that more than



80% had back problems. He thought that this was not good – nor very fair.

Dr. Ullman started his scientific research at the Sahlgrenska University Hospital, department for Occupational Orthopaedics in Gothenburg, internationally recognised for research in back trauma and injuries.

He developed measuring methods and techniques, pioneering the field of whole-body impact at sea, as well as analysing the human physiological and motoric response to shock and impact.

As Dr. Ullman was already famous for a number of epochal inventions in the field of human factors, ergonomics and injury prevention, the Swedish Coastguard asked him to create, based on his scientific results, technologies protecting people from injuries caused by impact exposure at sea.

The first organisations to standardise on Dr. Ullman's seats were the Swedish Coastguard, the Swedish Sea Rescue, the Dutch Sea Rescue KNRM and the UK Royal Marines.

After three decades Ullman Seats are still the world-leading brand and unsurpassed in performance. It is the defacto standard with over 11 000 seats in use, protecting people in more than 70 countries worldwide.

Operators today face ever increasing challenges, increasing speeds and more determined enemies, so the scientific research continues.

The continuous technical development is based on scientific evidence and on tight cooperation with end-users, old and new, like the US Navy Seal Teams, New Zealand and Australian Navies, Scandinavian and Middle Eastern Special Forces and Coastguards.

The Ullman Coat of Arms, dating back to 1685, has now been adopted as the seal for the Ullman line of products. It covers the front of this booklet.

The motto "Protegam Populus" translates to "Protecting People".





COMPACT
PAGE 9



BISCAYA
PAGE 10



PATROL
PAGE 11



DAYTONA
PAGE 18



DAYTONA CREW
PAGE 19



ECHELON SPORTBACK
PAGE 14



ECHELON HIGH BACK
PAGE 15



SISU FOLD UP
PAGE 30



BISCAYA BULLDOG
PAGE 30



STOWAGE BASE
PAGE 30



ATLANTIC
PAGE 16



ATLANTIC FOLD UP
PAGE 20



ATLANTIC CREW
PAGE 17



ARCTIC
PAGE 21

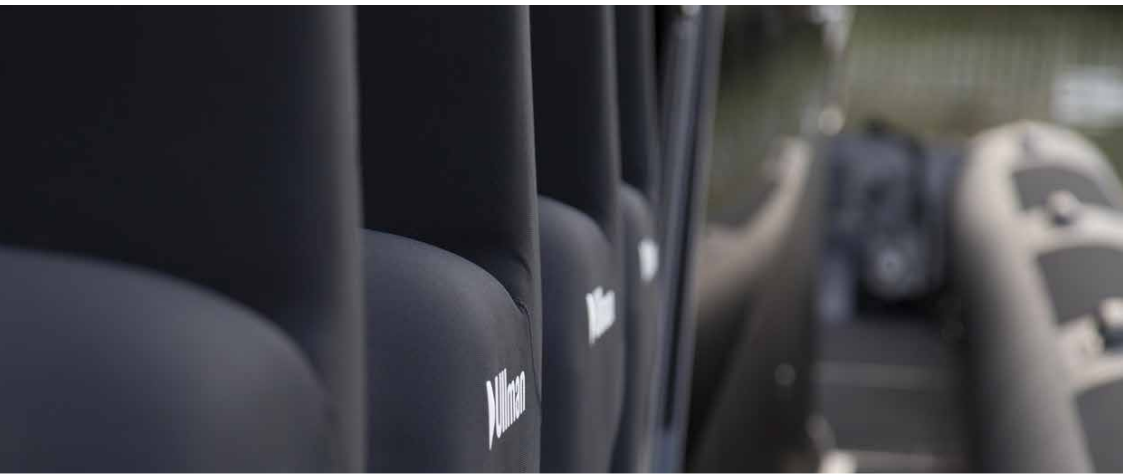

JOCKEY SEATS

Ullman Jockey seats allow use of both arms and legs to absorb impacts in the best possible way. They optimize the body posture into balanced straddling positions – the proven best to withstand impact forces – both vertical and lateral.

Ullman Semi Active Suspension System synergises with the muscular reflex protective system. In calm seas the suspension is soft and comfortable. In rough seas, it adapts to absorb the worst impacts. Built to protect people in all sea states

– THE SPACIOUS SEAT –

Ullman Compact Seat gives full impact protection while allowing the maximum free space in the cockpit.

The Compact Seat features shorter saddle sides and a lower backrest. With the handle on top, the Compact is very slender and takes up no more space than the person

seated. The seat is designed to fit in limited spaces and on boats where broad aisles and deck space is crucial. It is the lightest professional suspension seat on the market. The Compact is in service with many agencies world-wide – even on air droppable boats.

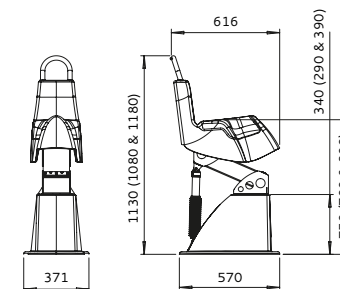

Compact

FEATURES

- » Full XLT Suspension
- » 150 mm Vertical Travel
- » Non-corrosive materials
- » Narrow back rest
- » U-handle
- » Watertight stowage pouch
- » Core lateral support

Weight	19 kg / 41,9 lbs
Stroke	150 mm
Damper	UD430
Materials	Stainless steel SS-EN 1.4462, Composite, Neoprene

Biscaya

FEATURES

- » Full XLT Suspension
- » 150mm Vertical Travel
- » Non-corrosive materials
- » High Backrest
- » Core lateral support
- » Two Grab Handles
- » Full length cushioning
- » Soft seat front edge

Weight	20 kg / 44 lbs
Stroke	150 mm
Damper	UD430
Materials	Stainless steel SS-EN 1.4462, AL-5083, Composite, neoprene

– THE ORIGINAL –

Ullman Biscaya Seat is the **no. 1 Suspension Seat in the world – the original Ullman seat.**

It has a high backrest and long saddle sides supporting the thighs in varied sitting positions. The Biscaya is developed for active use in the very worst of conditions.

It offers the safest postures and a suspension optimized to synergize with the human muscular protection system. Safe lateral stabilisation and lateral shock absorption. Two handles on the backrest provide stable support for the person seated or standing behind.

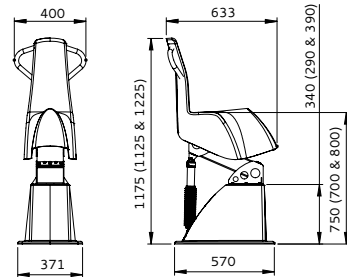

– PREMIUM COMFORT –

Ullman Patrol seat offers **exceptional comfort during long-range missions.**

This hybrid seat allows a wide variety of sitting positions. The Patrol seat is favoured by the most demanding users who spend days at a time riding and patrolling the oceans.

Derived from customer feedback, the Patrol features a soft and large sitting surface which allows you to alter your sitting position during long transits and patrol missions. Patrol is the most comfortable jockey seat on the out there.

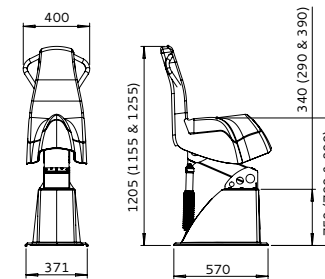

Patrol

FEATURES

- » Full XLT Suspension
- » 150mm Vertical Travel
- » Non-corrosive materials
- » High and Wide Backrest
- » Two Large Grab Handles
- » Core lateral support

Weight	22 kg / 48 lbs
Stroke	150 mm
Damper	UD430
Materials	Stainless steel SS-EN 1.4462, Marine grade aluminium, Composite, neoprene



BOLSTER & BUCKET SEATS

The Ullman bolster seats allow the operator to stand fully supported and protected from impacts and interact with the seat. The bolster seats also allow the operator to sit back in a reclined position, while still maintaining the S-shape of the spine. To secure optimal protection in all positions, the Ullman bolster seats optimizes the different body postures for handling both static and dynamic loads.

The bucket seat is a suspension seat inspired by power boats and F1 racing. Ullman bucket seats gives full support and protection for crew on board high speed boats where space is limited and light weight is essential. The Ullman bucket seats provide an anatomically optimal seating position with full lateral support. It is a proven platform that has been extensively tested by several elite units and adopted after having exceeded all expectations.

Echelon Sportback

FEATURES

- » Full 200mm 3D-Suspension
- » Optimised dimensions for easier integration in craft
- » Very light weight
- » Non-corrosive materials
- » Low Backrest for increased visibility.
- » Flat or Jockey Style front
- » Optional grab handles, armrests and footres

Weight	36 kg/79 lbs
Stroke	200 mm
Damper	UD530
Materials	Composite / Stainless Steel, HD Upholstery

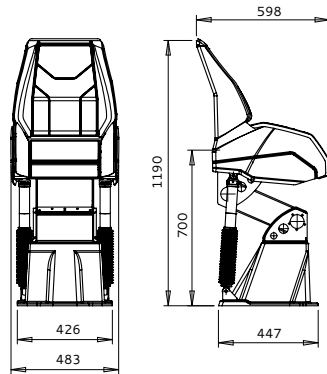

- FULLY OPTIMIZED -

The Echelon Sportback provides the advantages of a full bolster seat with minimal space requirements.

With uncompromized protective capacity and increased comfort, the Echelon gives the operator full support in all key interface areas. In this Sportback version,

the backrest is lower to allow full visibility throughout the platform.

The flat front facilitates ingress and allows the operator to assume a semi-standing position, with maintained shock mitigation and support. Also available with jockey-style front.

- THE PERFECT HYBRID -

The Echelon High Back has all the features of the sportback version - plus a high backrest, supporting the head.

The redesigned Jockey front has a rigid core, covered with shock absorbing foam. Echelon is the true hybrid

between a Jockey - and a Bolster seat. When seated back, the front provides lateral support by stabilising the insides of the knees. When used in the Jockey-position, the operator has full support and protection from impacts in all directions.

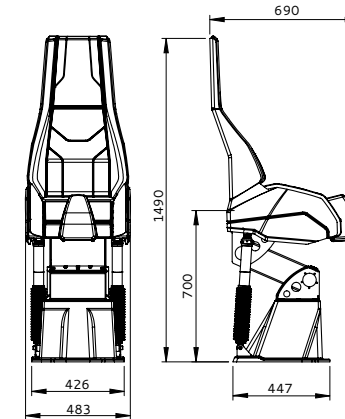

Echelon High Back

FEATURES

- » Full 200mm 3D-Suspension
- » Optimised dimensions for easier integration in craft
- » Very light weight
- » Non-corrosive materials
- » High back rest for head support
- » Flat or Jockey Style front
- » Optional grab handles, armrests and footres.

Weight	37 kg/80 lbs
Stroke	200 mm
Damper	UD530
Materials	Stainless steel SS-EN 1.4462, AL-5083, Composite, HD Upholstery

Atlantic

FEATURES

- » Twin UD530 Adjustable Damper (6-level)
- » Full ALM Spring Unit
- » Non-corrosive materials
- » 200mm Vertical Travel
- » Full carbon fibre back
- » High backrest
- » Lumbar support
- » Torso Lateral support
- » Thigh Lateral support

Weight	43.5kg/95 lbs
Stroke	200 mm
Dampers	UD530 Adjustable
Materials	Stainless steel SS-EN 1.4462, AL-5083, Carbon Fibre, Premium leather HD Upholstery

– THE CLASS LEADER –

Allow your body to work at its full potential at all times, in all positions.

In the Atlantic Seat, you can stand fully supported and shock-protected in a straddle position and interact with the seat. It also lets you sit back in a reclined position, still maintaining the S-shape of your spine.

Strap in and be ready for any challenge, confidently letting

the seat do all the work. To secure optimal protection in all positions, the Atlantic seat optimises the different body postures for handling both static and dynamic loads. It is designed for both open and cabin boats. The lateral suspension, the adjustable dampers and the multiple positions make the Atlantic seat the most versatile top-of-the-line seat to date.

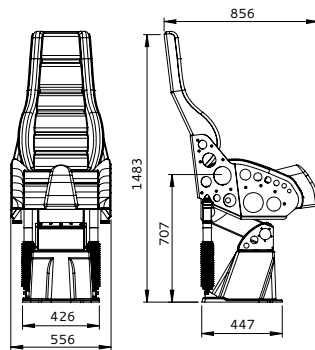

– PROFESSIONAL PROTECTION –

The safety of all passengers on board high-speed boats is our main focus.

The Atlantic Crew has the same size and shape as the Atlantic seat. Slightly lighter and less complex, this seat provides full protection and comfort and enables employers to equip vessels

with more seat to protect their most valuable assets – the workforce.

It is popular in the wind farm and offshore industry, where strict legislation requires the best proven shock mitigation. The Arctic seat comes with self-adjusting 200mm dampers and marine grade vinyl upholstery.

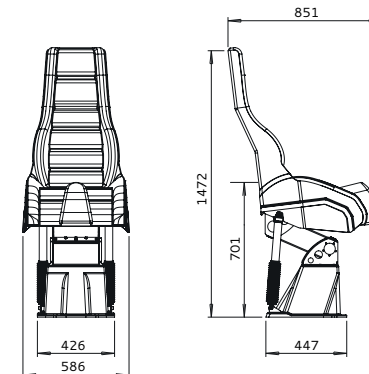

Atlantic Crew

FEATURES

- » Twin UD530
- » Full ALM Spring Unit
- » Non-corrosive materials
- » 200mm Vertical Travel
- » Strategic Unibody Composite Shell
- » Torso Lateral support
- » Thigh Lateral support

Weight	41.9 kg/92 lbs
Stroke	200 mm
Dampers	UD530
Materials	Stainless steel SS-EN 1.4462, AL-5083, Composite, HD Upholstery

Daytona

FEATURES

- » Anatomic seat and backrest
- » Full lateral support
- » Ultra light weight (22kg)
- » Twin UD430 Adjustable
- » DLM 3D Spring Unit
- » 150 mm Vertical Travel
- » Strategic Carbon Fibre Unibody

Weight	22 kg / 53 lbs
Stroke	150 mm
Dampers	UD430 Adjustable
Materials	Stainless steel SS-EN 1.4462, AL-5083, Carbon Fibre, Premium leather HD Upholstery

- EXTREME PERFORMANCE -



Daytona was developed for the most advanced Special Forces high speed craft in the world.

After extensive testing in extreme sea states, it became the new standard.

The anatomic shape and upholstery, the ultra light

carbon fibre unibody and the lateral suspension makes it ideal for the most demanding missions.

Daytona seat gives full support and maximum protection when space is limited, weight is crucial and COG needs to be low.

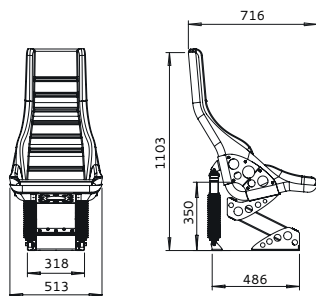

- ENDURANCE & PROTECTION -



Everyone on board should be equally protected. Daytona Crew is a cost effective version of the Daytona Seat.

The composite unibody makes the seat light and strong. The lateral support cushioning in both seat and backrest adapts to the operator, allowing a

wide range of operator body sizes.

Daytona Crew is suitable for large vessels as well as for small high speed craft. The seat can be fitted with armrests, footrest and harnesses. The low profile allows for easy integration in all craft.

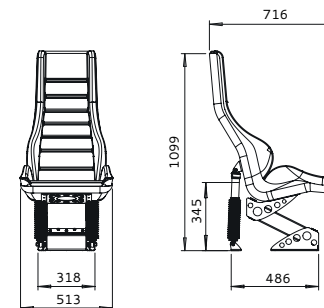

Daytona Crew

FEATURES

- » Anatomic seat and backrest
- » Lateral support
- » Self Adapting Cushioning
- » Light weight (25kg)
- » Twin UD430
- » DLM 3D Spring Unit
- » 150 mm Vertical Travel
- » Strategic Composite Unibody

Weight	25 kg / 57 lbs
Stroke	150 mm
Dampers	UD430
Materials	Stainless steel SS-EN 1.4462, AL-5083, Composite, HD Upholstery

Atlantic Fold Up

FEATURES

- » Twin UD530 Adjustable (6-level)
- » Full ALM Spring Unit
- » 200mm Vertical Travel
- » Full carbon fibre back
- » Lumbar support
- » Torso Lateral support
- » Thigh Lateral support
- » Fold-up seat pan
- » Flat front

Weight	43.5kg / 96 lbs
Stroke	200 mm
Dampers	UD530
Materials	Stainless steel SS-EN 1.4462, AL-5083, Carbon Fibre, Premium leather HD Upholstery

– THE TRANSFORMER –



Based on the proven Atlantic seat, the fold-up version allows the front half of the seat pan to shift upwards and thus becomes a lumbar support.

Developed together with the Colombian Navy and Coast Guard, this Atlantic seat can

be transformed into a standing bolster, allowing ample space for leaning or standing clear in front of the seat.

Folded down, the seat becomes a full Atlantic seat with ergonomics and comfort for long range missions.

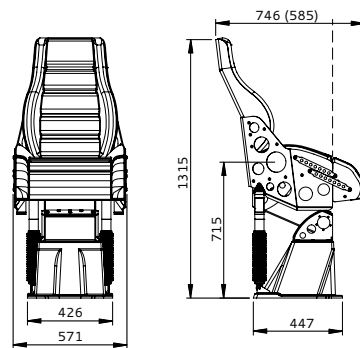

– HIGH SEA RACING –



Originally developed in cooperation with the Norwegian Special Forces, the Arctic Seat is the most active of our bucket seats.

Compared to the Atlantic Seat it has a shorter seating pan and a lower backrest. With a less reclined backrest the seat puts you in a more active driving position.

The seat allows both straddling and reclined seating positions.

This solid bucket seat is suitable for limited spaces and fast vessels where you need to be able to alter your seating position. A multi position seat with good lateral support

The Arctic seat is used by offshore race teams and special forces around the globe.

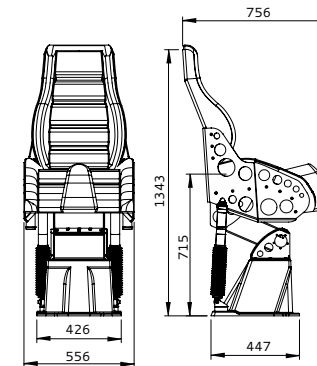

Arctic

FEATURES

- » Twin UD530 Adjustable (6-level)
- » Full ALM 3D Spring Unit
- » 200mm Vertical Travel
- » Full carbon fibre back
- » Low back rest
- » Lumbar support
- » Torso Lateral support
- » Thigh Lateral support

Weight	41.5kg / 91 lbs
Stroke	200 mm
Dampers	UD530 Adjustable
Materials	Stainless steel SS-EN 1.4462, AL-5083, Carbon Fibre, Premium leather HD Upholstery

Seat interface alternatives



**JOCKEY
POD MOUNT**

This configuration interfaces with the Ullman Jockey Pods, which comes in three heights, giving a seating height of 700, 750 or 800mm from deck.



**JOCKEY
BOX MOUNT**

This configuration provides same-level mounting surface for both spring-unit and damper, allowing the seats to be mounted on square bases, flat surfaces or extending over an edge. This can be especially useful when retro-fitting seats to existing platforms.



**BOLSTER
POD MOUNT**

Compatible with all Atlantic and Echelon seats, the Pod mount provides a complete solution that mounts to the deck. The pod can be equipped with a hatch to allow access and stowage.



**BOLSTER
BOX MOUNT**

This configuration, where the dampers are mounted on the backrest instead of under the seat allowing the seats to be mounted on custom bases and existing structures. Also fully compatible with all accessories such as sliders and footrests.



ACCESSORIES

Modularity, flexibility and customization are central elements in all Ullman Dynamics products. This also applies to our whole range of accessories. Every single accessory is designed for 100% compatibility, ensuring uncompromized

function over time. This category also contains information about the Ullman Steering System, the Ullman Console and how Ullman Dynamics can help optimizing the cockpit design.



FOLDABLE FOOT REST

CNC-cut ALU 7075-T6. Super grip diamond shape surface and anti-slip ridge along outside surface allows custom height setting. The large foot pad provides support for the whole front foot. Free movement of heel allows the muscular system full motion.



DECK INSERT BOLTS

For mounting on any deck.

Bolts fit flush to deck, no tripping hazard. Allows for quick and easy removal of the seats and leaves nothing sticking out. Outside thread: M20 Inside thread: M8.



ADJUSTABLE ARMRESTS

The 7 axis adjustable armrest can be set up and adjusted exactly where you want it. It can be fitted with Joysticks, Trackballs, Pistol Grip Handles etc. Fits most seats.



COATED SPRING UNIT

Black powder coating is available on all parts. With black spring unit, and coated handles and the matte upholstery, nothing will reflect light. No one will see you coming.



MULTI BASES

These bases can be built to accommodate 1, 2 or more seats in line. This allows ample storage space with hatches. Bases can be welded with aluminium plates or constructed in composite.



SLIDING SYSTEMS

All sliders in the Ullman Slider range are ultra strong, very lightweight and smooth sliding, allowing you to set the optimal position of the seat easily and with confidence. Available for all Ullman seats.



FRONT SEAT HANDLE

When Ullman Jockey Seats are mounted without a console or another seat in front, a front seat handle is recommended. This gives the rider the support necessary to hold on and control the body at high impact.



COATED HANDLES

Handles with thermal insulation can be fitted to any Ullman seat. This polymer coating also gives a softer surface and higher friction than stainless steel. It is very useful for cold climates and in situations where anti-glare is important.



ADJUSTABLE DAMPER

Hard anodized aluminium, internal components of acid proof stainless steel 316L. Easy set-up dial with 6 level adjustable compression gives you a wide range from soft to stiff. Stroke: 150 or 200mm.



TRACK SYSTEMS

Quick Release system using aircraft cargo rails in combination with a special nut and washer machined from SS 316L. Takes about 20 seconds to undo and fasten. Allows for quick and easy modularization of a deck or a cabin.



CORDURA SEAT COVERS

Tightly fitted cover for the jockey seat range. It is designed to stay on the seat all the time. Cordura is a heavy duty nylon fabric used in workwear and tactical clothing. It has the highest abrasion grading available. Now also available with MOLLE system.



2 & 4 POINT HARNESS

Highly adjustable harness for secure seating. Allows you to relax and let the seat do the job. Where there is risk for capsizing, crews on cabin boats are recommended to use lap belts. This is to prevent head and neck injuries when a boat gets turned upside down.

— AT YOUR SERVICE —

Custom Cockpit Design



User interfaces and cockpit layout are crucial to the ergonomics and performance of the craft.

Therefore we make sure that every cockpit where a seat is installed is optimised for human function and safety.

We work closely with boat builders, assisting designers and naval engineers to secure peak performance and 100% optimal function for the user. It's all about protecting people.

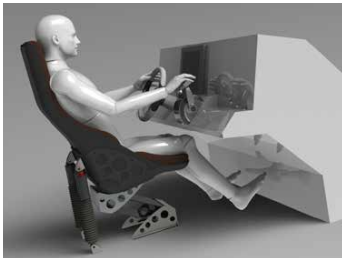

Optimize Cockpit Ergonomics

This generic helm console provides good visibility forward, convenient location of navigation screens, easy access to the helm and throttle control, and ample space for feet and legs, even in rough conditions.

(1) To minimize the deadspace distance between the screen and the forward field of vision, the console's top surface should slant down forward. Remember that the far end of the top surface sets the lower limit for the field of vision, and helmsmen need to see the bow clearly.

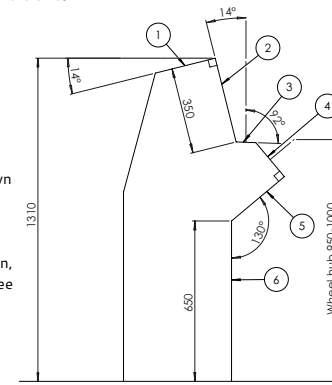

(2) The plotter screen should be mounted on a plane optimally inclined 12°–16° forward from vertical. To minimize reflected glare from the sky, the screen should be mounted so a perpendicular line through its center points to just below the operator's chin.

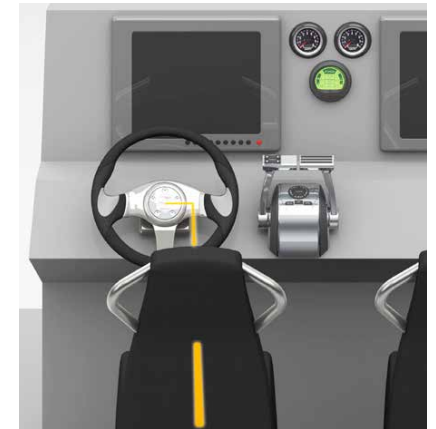

The wheel should be offset slightly to port from a fore-and-aft line drawn through the driver. This permits better postural balance, as the operator's hands at the helm and throttle are symmetrical to the torso.

Full article on Designing Cockpits for Speed available at www.ulmandynamics.com

Ullman Console – THE EPITOME OF ERGONOMICS –



The Ullman Aerodynamic Console is designed and shaped to reduce air resistance while protecting the crew from wind and spray.

It is designed for optimal ergonomics in the most challenging operational conditions. It can be used for port or starboard helm position and provides optimal positioning for steering wheel and throttle.

The console is built in GRP sandwich and is strategically reinforced to withstand high impacts. It is fitted with a 10 mm (3/8") heavy-duty windscreen.

The Ullman Console can be used with a traditional steering wheel or with the Ullman Steering Bar System. The dashboard holds twin 15 inch chart plotters. There is an easy-access hatch for stowage, installation of electronics and inspection.

Ullman Aerodynamic Console optional accessories include grab handles and various locking mechanisms. Standard colours are black or white. Customer specified gel coat colours are available to order.

Custom made



All upholstery for the Bolster and Bucket seats is hand-sewn in Sweden by master craftsmen with a long tradition of working with the most exclusive and demanding materials. This allows us to make custom upholstery in a wide range of materials, stitchings and colors to meet all customer requirements. We use the highest quality Swedish leather treated for high durability under heavy duty use. Various kinds of vinyl and nylon are also available. To match other upholstery in craft, we can also work with materials supplied by the customer. The picture above shows a back cushion for Daytona with ventilated leather on the center panel.

A wide range of surfaces and finishes for the seat unibody is also available. All composite seats can be custom made with any color gel-coat, matte or polished finish, foil wrapping or hydro dipping. The Carbon Fibre seats – Daytona and Atlantic seats are clear-coated, and can also be foiled or dipped if requested. The aluminum frames are hard anodised and can be made in most colours. The picture above shows a carbon fiber foil-wrapped Echelon low-back seat.

Custom products

For customers with special requirements, we create custom product to fit any operational requirements. Some examples are steering systems, foldable seats and custom fastening solutions.

The **Narrow handles** provides a wide grip while keeping the total width of the seat to a minimum.

This makes for wider aisles and a close grip for the person behind.

The Ullman jockey seats are available in a shorter version called **Bulldog**, allowing tighter spacing, fitting more seats in any assigned space.

The box shaped **Stowage base** provides 45 liters of easily accessible stowage space. In the twin configuration it can be used as a weapons locker, holding several complete rifles.

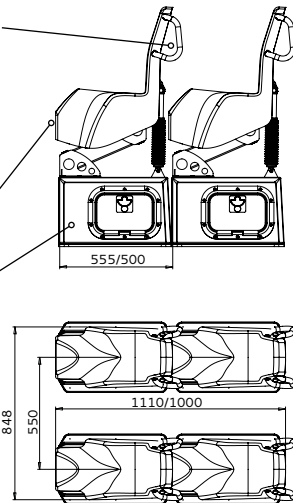

The **Ullman steering bar system** gives full control of throttle and steering while holding on. In active use by coast guard and sea rescue. Significantly increases maneuverability and reduces the time to train new boat operators.



The **SISU fold-up seat** is designed to free up space behind the seat. They can also be stacked very tightly together when not used.

Developed for the Finnish special forces, It is favoured by boarding teams across the globe.

Why Ullman seats are superior

Ullman Seats are proven by independent evidence based science to provide better shock mitigation for humans than any other tested seats. They are the result of 25 years of scientific research and development.

Work in synergy with the human body
Developed based on medical science.

Reduce risk of injuries*
Reduce physical fatigue*
Can reduce number of impacts >2g by 76%.
Can reduce severity of impacts by 62%.*

Unique 3-dimensional suspension
prevents impact injuries and ejections.
Ejections can cause severe injuries.
All Ullman seats have lateral mitigation.

Designed to not bottom-out
Bottoming-out is dangerous. It can give up to 3 times amplification of impacts. It can cause injuries and ejections. The progressivity of Ullman suspension, prevents bottoming out.

Reduce human vibration exposure
Vibrations that cause physical fatigue.
The suspension is progressive and absorbs the continuous vibrations.

12 000 seats in professional use
in 70+ countries, since up to 20 years.
Zero injuries and Zero ejections reported.

Do not break
Structural failure causes injuries and ejections. Failure causes down-time and repair costs. All Ullman seats and accessories are designed with a safety factor of 2.0 or greater.

Do not corrode
Corrosion limits lifetime and causes failures. Ullman seats are built using only non-corrosive materials, such as Super Duplex steel and multi-composites.

Do not need maintenance
Maintenance causes down-time. Ullman seats have no joints or moving parts which eliminates the need for lubrication and costly maintenance. **

3-year worldwide warranty extendable up to 10 years. "They just don't break".

The lightest professional seats on the market gives more payload, higher speed and range.

The smallest footprint
Frees deck space for more cargo and crew.

EU Legislation on Impact & Vibration
The EU-directive requires use of the most effective shock reduction available. Manufacturers and employers can be held liable for injuries.

Height adjustment where it is useful
Tall operators don't want to sit higher. Short operators don't want to sit lower. Seated eye-height level is crucial. It differs very little between tall and short people. Height adjustment shall be for the feet.

Standard in Navies worldwide
Several professional agencies world-wide have thoroughly, scientifically evaluated various seats and adopted Ullman seats as standard.

Lowest life cycle costs
Large sums are saved as the seats normally last the lifetime of the boat.

* Independent scientific proof sent on request.
** Dampers should be checked every 3 years.

Fatigue

Travelling on high-speed boats is physically exhausting. High energy consumption makes you very tired and affects physical performance. Ullman suspension seats significantly reduce energy consumption compared to fixed seating.

Running performance is significantly reduced in military personnel after a high-speed transit when using fixed seats. Using Ullman Jockey Seats increases post-transit physical performance and endurance by 30.5% compared to fixed seats.

The test below shows zero reduction in running distance of passengers on Ullman seats, while passengers on fixed seats reduced their running distance by 358 meters.

Ullman Seats not only reduce the risk of injury but they also enhance the operational performance of the boat crew and passengers. When operators are challenged with military or lifesaving tasks, the difference between exhausted and alert could mean life or death.

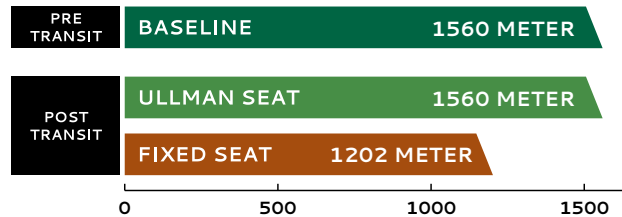

The graph on the opposite page shows a recording done with a DaccR.

Green = Speed over ground
Blue = g-force on boat
Red = g-force on driver in Ullman seat

It shows the significant shock mitigation of the Ullman seats.

PLATFORM
Two military HSC 28' Arctic RIB (Halmatic)
TRANSIT DETAILS
HSC ran side-by-side
Duration: 3 hrs
Sea-state: 2-3
Speed: 40 knots
SEATING
Standing In-service fixed seats
Ullman Jockey Seat Biscaya

Myers, S. D., Dobbins, T. D., King, S., Hall, B., Gunston, T., Holmes, S. R., & Dyson, R. (2008). The effectiveness of shock mitigation technology in reducing motion induced fatigue in small high speed craft. In *Pacific 2008 International Maritime Conference*.

The Impact of Shock

The human body has a complex system of muscular reflexes, developed and evolved to protect us from injury.

Reflexes are designed to trigger reactions in our muscles, to protect us against impacts. The muscular response is obvious in our legs, but is also at hand in our arms, torsos and necks. When muscles react to impact, they contract – to serve as shock absorbers – and to stabilise the spine and joints.

Sitting in a traditional seat always puts your spine into a C-shape. – Sitting hurts. Then the weight of the head is hanging forward of its supporting structures in the neck. This is the worst position for the spine to be in when exposed to a vertical impact. There is risk for head jolts. This can cause whiplash-like distortion injuries and disk ruptures in the neck. Even the risk of vertebral fractures and lumbar disk hernias is much higher with the spine in this C-shape.

Standing keeps the spine in its natural, balanced, S-shaped posture. So race-boat drivers have often chosen to stand. However, standing multiplies impact forces and thus may cause injuries to the spine.

The Ullman Seats are developed with a special semi-active suspension system, designed to synergise with nature's muscular, reflex-based, protection system. All Ullman seats are also designed to maintain the optimal S-shape of the spine and balance of the head at all times.

The progressive patented suspension system and the synergies with the biologic response, neutralises the resonance effects that make other suspension seats capable of bottoming out – multiplying impacts.

Ullman Seats are developed based on pioneering medical science. They are independently scientifically validated and proven to give the most effective shock protection of all seats.

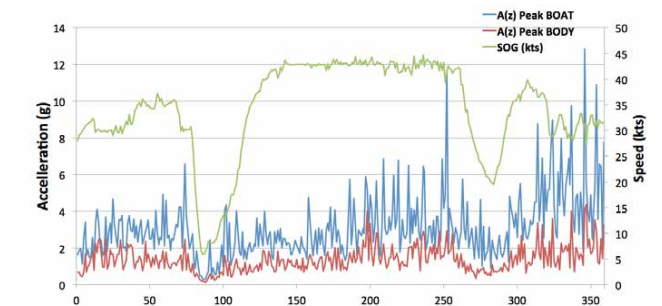

References



References





WORLD LEADER IN SUSPENSION SEATING

ULLMANDYNAMICS.COM | REQUEST@ULLMANDYNAMICS.COM | SE (MAIN) : +46 31 708 2600
US: (757) 383 8385 | FR: +33 970 407088 | SG: +65 6464 6122